

Engineering drawing label reference examples

One small screenshot per label, sourced from the uploaded books and aligned to the 18 classes listed in *engineering_drawing_label_schema_pipeline_v1.xlsx*. These are reference snippets for visual consistency, not exhaustive definitions.

ID	Class	Priority	Group
1	title_block	P0	region
2	revision_block	P0	region
3	parts_list_bom	P0	region
4	notes_block	P0	region
5	general_tolerance_note	P1	region
6	drawing_view	P0	region
7	section_cutting_plane	P1	symbol
8	detail_callout	P1	symbol
9	item_balloon_find_number	P0	symbol
10	dimension_cluster	P0	symbol_group
11	leader_callout	P1	symbol_group
12	hole_callout	P1	text_symbol_group
13	thread_callout	P1	text_symbol_group
14	datum_symbol	P0	symbol
15	feature_control_frame	P0	symbol
16	surface_finish_symbol	P1	symbol
17	weld_symbol	P1	symbol
18	section_hatch_region	P2	region

1. title_block

Annotation unit: Whole title block area as one box

Include: Title/name, drawing number, company, scale, units, approvals grouped in one block

Source: Engineering Drawing and Design (Jensen & Hessel), page 50.

AMT	DET	STOCK SIZE	MAT.
NORDALE MACHINE COMPANY PITTSBURGH, PENNSYLVANIA			
MODEL _____			
PART NAME _____			
PART NO. _____			
OPERATION _____			
FOR USE ON _____			
METAL _____ DIE CLEARANCE _____			
TOLERANCE: $\pm 0.5\text{mm}$ UNLESS OTHERWISE SPECIFIED METRIC			
LAYOUT _____		DRAWN _____	
CHECKED _____		APPROVED _____	
SCALE _____		DATE _____	
FROM B. P. _____		DATED _____	
SHEETS	SHEET	NO.	

Basis in schema: NASA title block requirements; workbook notes/title block; Bertoline title block/scale/general tolerance

2. revision_block

Annotation unit: Whole revision table/block

Include: Vertical or horizontal revision table

Source: Introduction to Graphics Communications for Engineers (Bertoline), page 267.

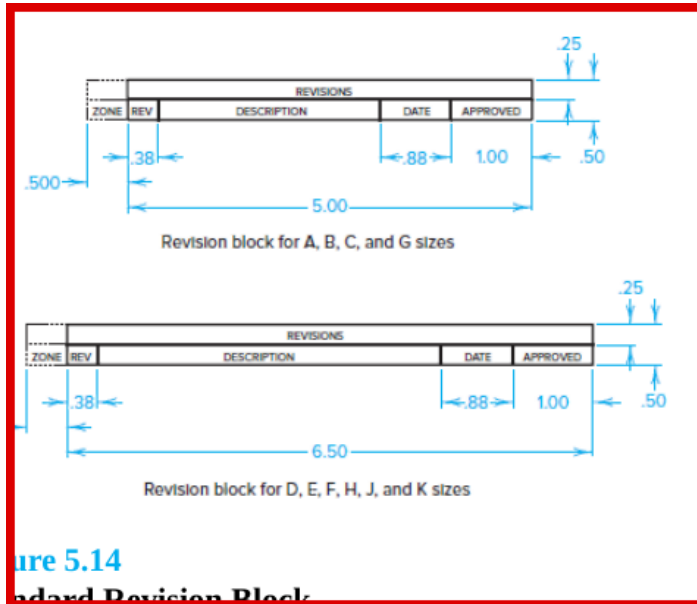

Basis in schema: Bertoline revision block; Jensen revision tables

3. parts_list_bom

Annotation unit: Entire BOM / parts list table

Include: Tabular material or item list

Source: Engineering Drawing and Design (Jensen & Helsel), page 50.

QTY	ITEM	MATL	DESCRIPTION	PT NO.
1	BASE	G1	PATTERN # A3154	1
1	CAP	G1	PATTERN # B7156	2
1	SUPPORT	AISI-1212	.38 × 2.00 × 4.38	3
1	BRACE	AISI-1212	.25 × 1.00 × 2.00	4
1	COVER	AISI-1035	.1345 (# 10 GA USS) × 6.00 × 7.50	5
1	SHAFT	AISI-1212	∅1.00 × 6.50	6
2	BEARINGS	SKF	RADIAL BALL # 6200Z	7
2	RETAINING CLIP	TRUARC	N5000-725	8
1	KEY	STL	WOODRUFF # 608	9
1	SET SCREW	CUP POINT	HEX SOCKET .25UNC × 1.50	10
4	BOLT—HEX HD—REG	SEMI-FIN	.38UNC × 1.50LG	11
4	NUT—REG HEX	STL	.38UNC	12
4	LOCK WASHER—SPRING	STL	.38-MED	13

NOTE: Parts 7 to 13 are purchased items

Basis in schema: NASA list of materials; Bertoline parts list; assembly drawing sources

4. notes_block

Annotation unit: Whole general notes area

Include: Ordered notes, process notes, flag-note lists

Source: Interpreting Engineering Drawings (Branoff), page 394.

Interpreting Engineering Drawings

ASSIGNMENT:

NOTE: ALL ASSIGNMENTS TO BE SKETCHED ON ONE INCH GRID SHEETS (.10 IN. SQUARES)

1. SKETCH THREE DIFFERENT PERMISSIBLE DEVIATIONS (SIMILAR TO FIGURE 44-2) FOR A RECTANGULAR PART .80 X 1.50 X .50 IN. THICK HAVING A TOLERANCE OF ± 0.05 IN. ON THESE DIMENSIONS. ADD DIMENSIONS.
2. MAKE A SKETCH, COMPLETE WITH DIMENSIONS, OF A RING AND PLUG GAGE TO CHECK THE HOLE AND SHAFT IN FIGURE 1.
3. MAKE A SKETCH OF THE PART SHOWN IN FIGURE 2. APPLY TWO FEATURE CONTROL FRAMES TO THE PART: ONE FRAME TO DENOTE CIRCULARITY (ROUNDNESS), THE OTHER FRAME TO CONTROL STRAIGHTNESS OF THE SURFACE OF THE CYLINDRICAL FEATURE.
4. MAKE A SKETCH OF THE PART SHOWN IN FIGURE 3. ADD THE FOLLOWING GEOMETRIC TOLERANCES TO THE SKETCH:
(A) SURFACE "A" IS TO BE STRAIGHT WITHIN .005 IN.
(B) SURFACES "B" AND "C" ARE TO BE STRAIGHT WITHIN .008 IN. USE A MINIMUM OF TWO DIFFERENT METHODS OF CONNECTING THE FEATURE CONTROL FRAME TO THE SURFACES REQUIRING STRAIGHTNESS CONTROL.
5. MAKE A SKETCH OF THE PART SHOWN IN FIGURE 4. ADD THE FOLLOWING STRAIGHTNESS TOLERANCES TO THE SURFACES.
(A) SURFACE "A" - .002 IN.
(B) SURFACE "B" - .001 IN.
(C) SURFACE "C" - .005 IN.
6. WHAT IS THE MAXIMUM PERMISSIBLE DEVIATION FROM STRAIGHTNESS IF THE RADIUS IN FIGURE 5 IS
(A) .498 IN.
(B) .500 IN.
(C) .502 IN.

Basis in schema: NASA notes on sheet 1; Hanifan notes complete/unambiguous

5. general_tolerance_note

Annotation unit: The general tolerance statement as one box

Include: UNLESS OTHERWISE SPECIFIED type note near title block

Source: Engineering Drawing and Design (Jensen & Helsel), page 50.

FOR USE ON _____
METAL _____ DIE CLEARANCE _____
TOLERANCE: ± 0.5 mm UNLESS OTHERWISE SPECIFIED METRIC
LAYOUT _____ DRAWN _____

Basis in schema: Bertoline general tolerance note

6. drawing_view

Annotation unit: Boundary of a single orthographic or pictorial view

Include: Front/top/side/isometric or enlarged view

Source: Engineering Drawing and Design (Jensen & Helsel), page 115.

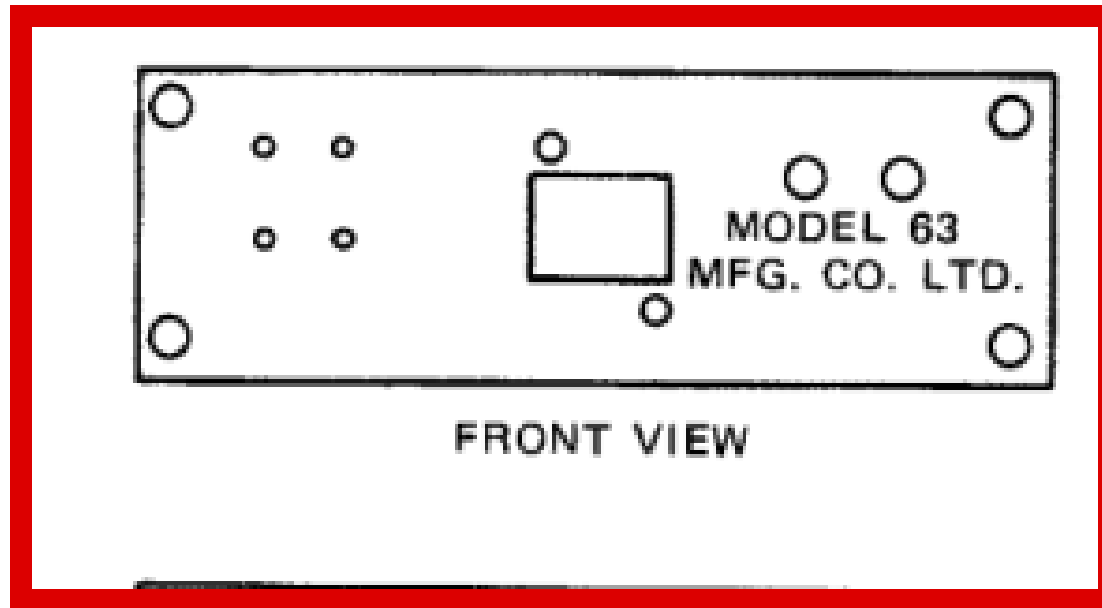

Basis in schema: Workbook orthographic views, view relationships, necessary views

7. section_cutting_plane

Annotation unit: Entire cutting-plane indicator including arrows and label

Include: A-A, B-B section indicators

Source: Engineering Drawing and Design (Jensen & Hesel), page 251.

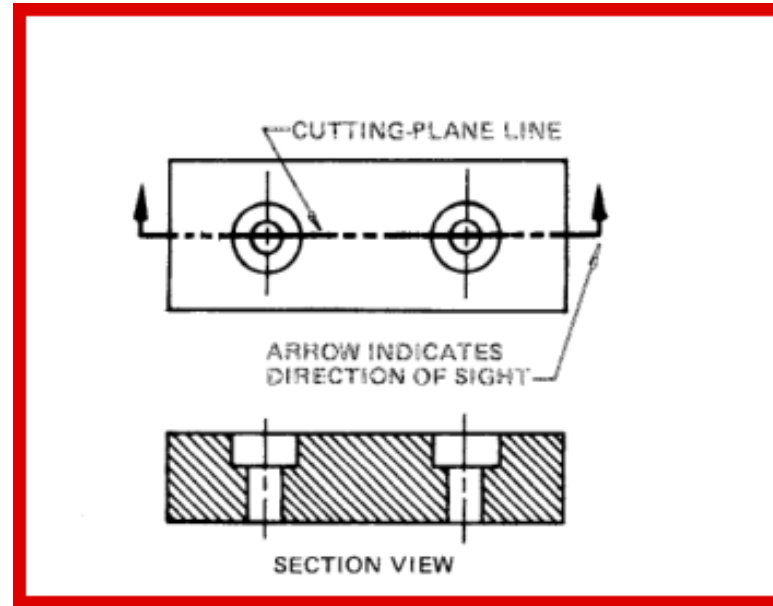

Basis in schema: Workbook section view practice; NASA view/detail lettering

8. detail_callout

Annotation unit: Circular/detail identifier with leader

Include: DETAIL A, ENLARGED, view reference markers

Source: Engineering Drawing and Design (Jensen & Helsel), page 115.

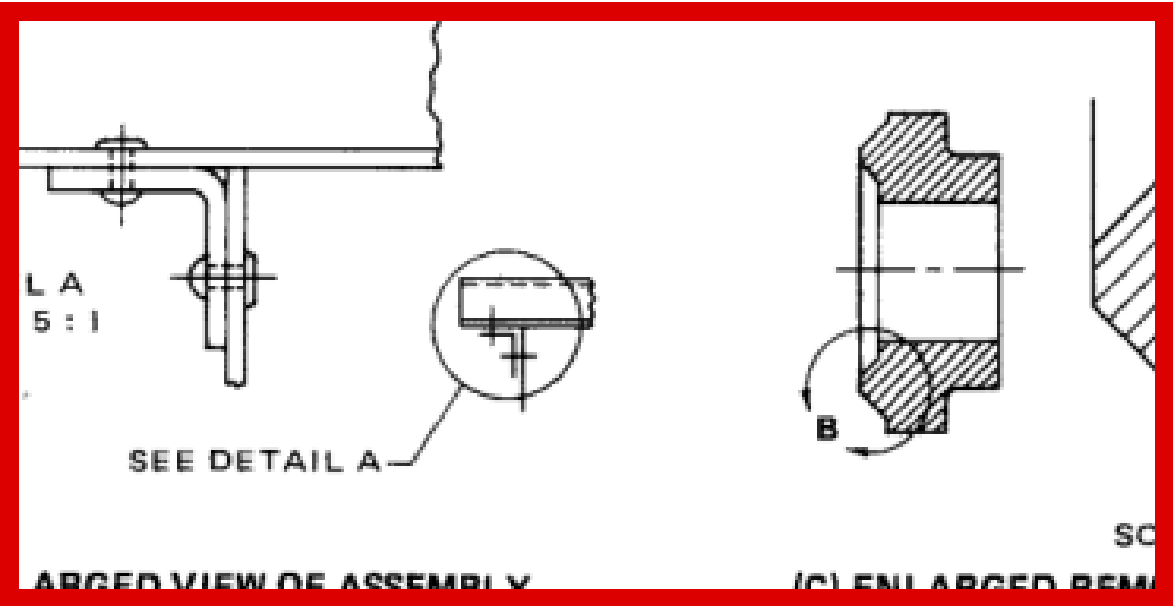

Basis in schema: NASA view/detail identifiers

9. item_balloon_find_number

Annotation unit: Balloon and number together

Include: Assembly item identifiers/find numbers

Source: Introduction to Graphics Communications for Engineers (Bertoline), page 266.

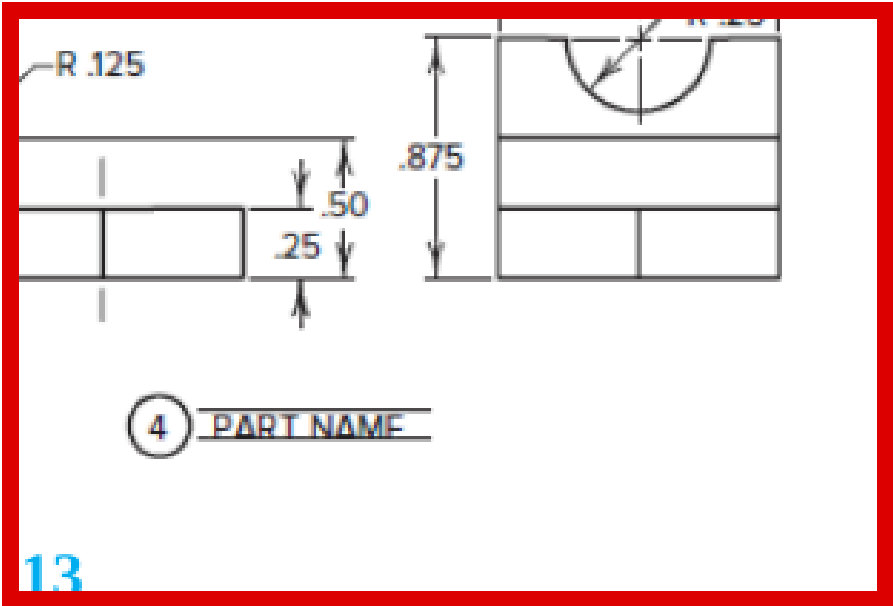

Basis in schema: NASA item find number rules; Bertoline balloons

10. dimension_cluster

Annotation unit: Dimension text + arrows + line as one object

Include: Linear, angular, radius, diameter dimension group

Source: Engineering Drawing and Design (Jensen & Helsel), page 202.

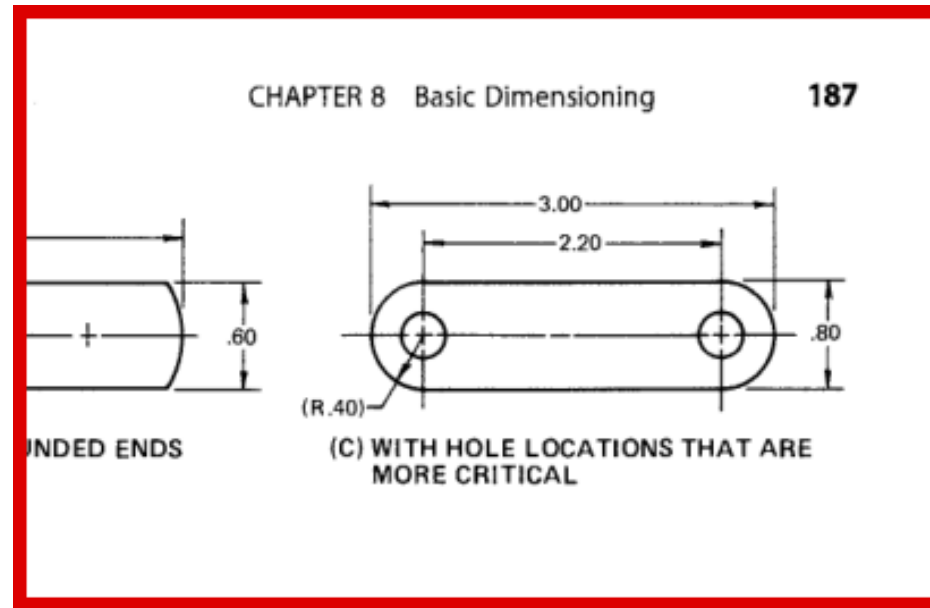

Basis in schema: Workbook dimensioning; Hanifan all features dimensioned/toleranced

11. leader_callout

Annotation unit: Leader line plus attached note/callout text

Include: Feature notes, flag notes, item callouts tied to geometry

Source: Interpreting Engineering Drawings (Branoff), page 138.

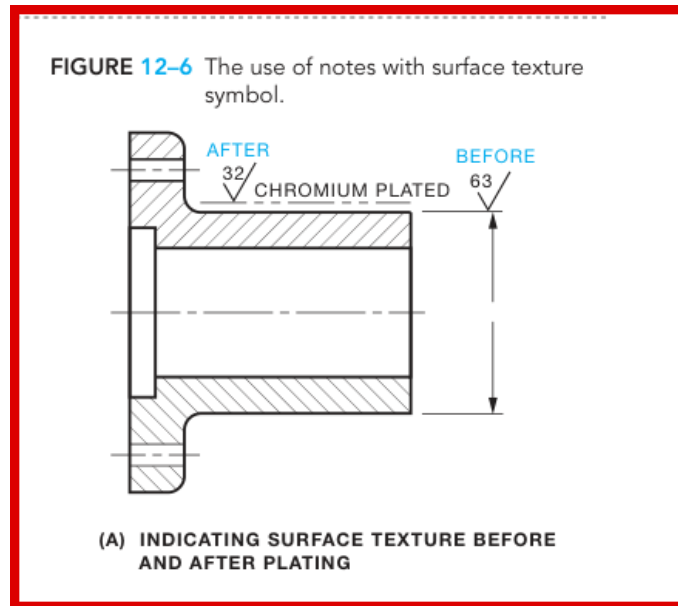

Basis in schema: Bertoline leader lines; assembly references

12. hole_callout

Annotation unit: Complete hole note string

Include: Ø, THRU, CSK, CBORE, depth, quantity callouts

Source: Engineering Drawing and Design (Jensen & Hessel), page 202.

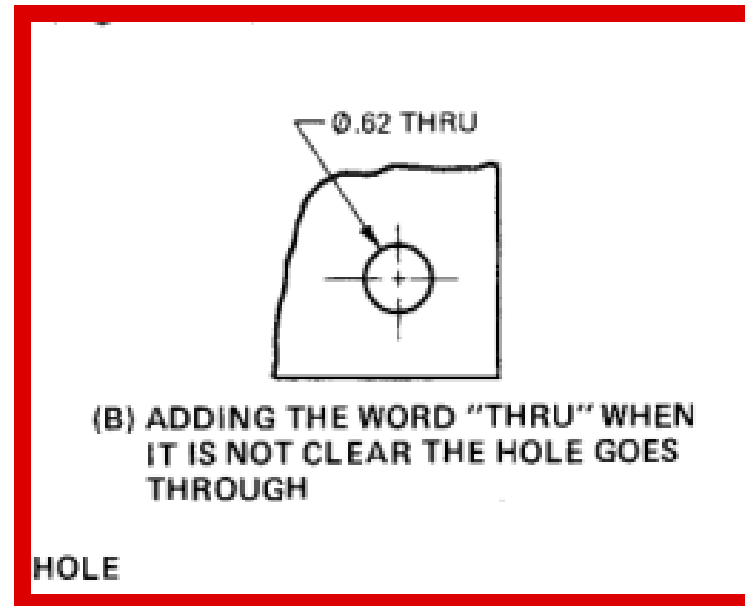

Basis in schema: Hanifan hole size/tolerance checks

13. thread_callout

Annotation unit: Complete thread specification string

Include: M6x1, 1/4-20 UNC, thread standards note

Source: Engineering Drawing and Design (Jensen & Helsel), page 282.

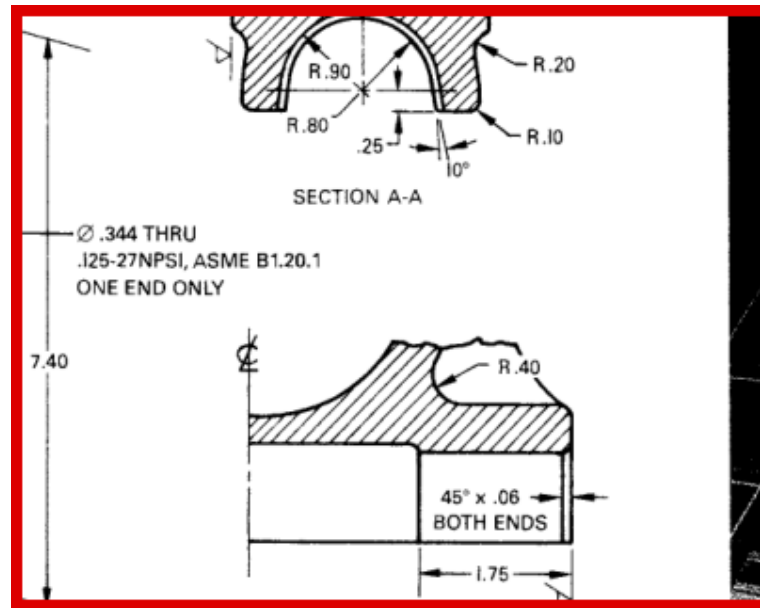

Basis in schema: Workbook threaded fastener; Jensen thread examples

14. datum_symbol

Annotation unit: Datum feature symbol with attached leader/triangle if present

Include: A, B, C datum identifiers

Source: Engineering Drawing and Design (Jensen & Hessel), page 547.

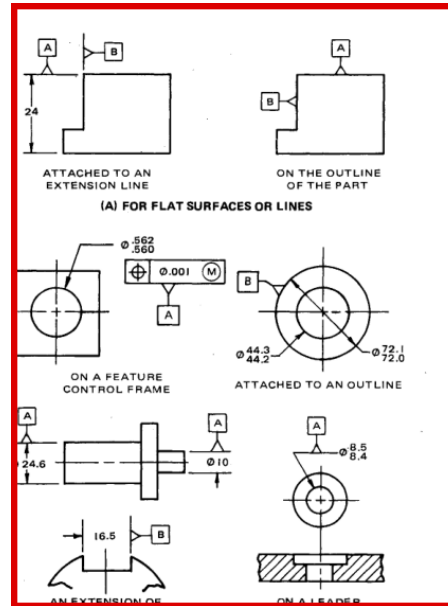

Basis in schema: NASA datums; Hanifan datum logic/accessibility

15. feature_control_frame

Annotation unit: Entire GD&T; frame as one box

Include: Single or multi-segment FCF

Source: Engineering Drawing and Design (Jensen & Helsel), page 549.

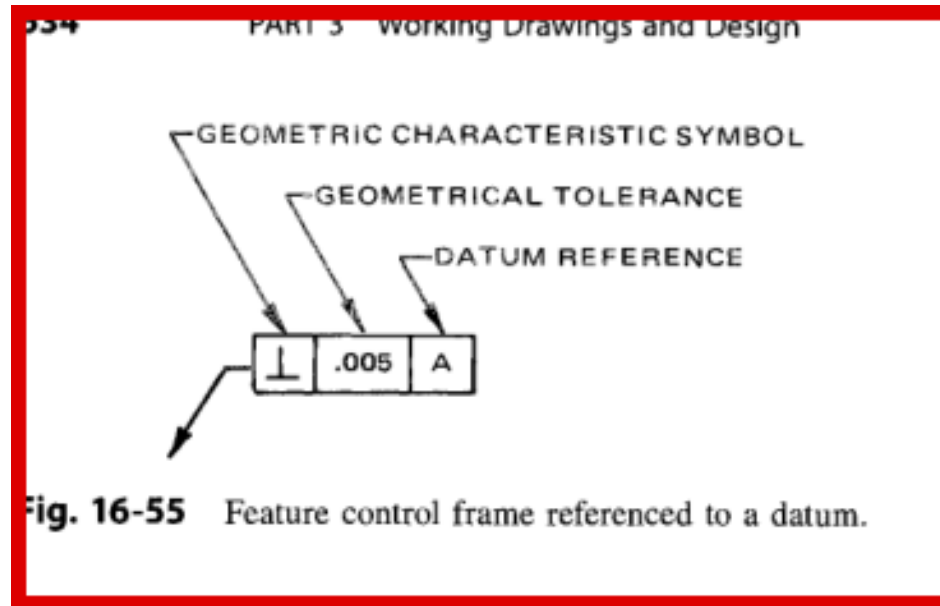

Basis in schema: Hanifan FCF and GD&T; error discussion

16. surface_finish_symbol

Annotation unit: Whole surface texture symbol and value

Include: Ra/roughness symbols

Source: Interpreting Engineering Drawings (Branoff), page 137.

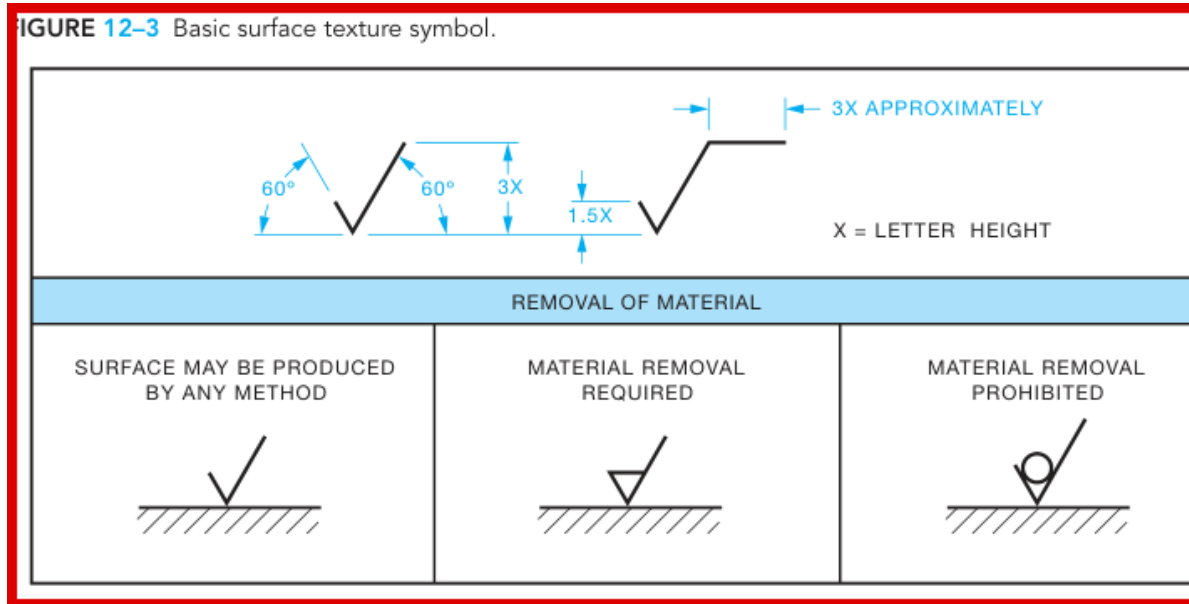

Basis in schema: NASA machine finish / applied finish requirements

17. weld_symbol

Annotation unit: Weld symbol plus tail/reference where connected

Include: Fillet, groove, etc. weld annotations

Source: Interpreting Engineering Drawings (Branoff), page 311.

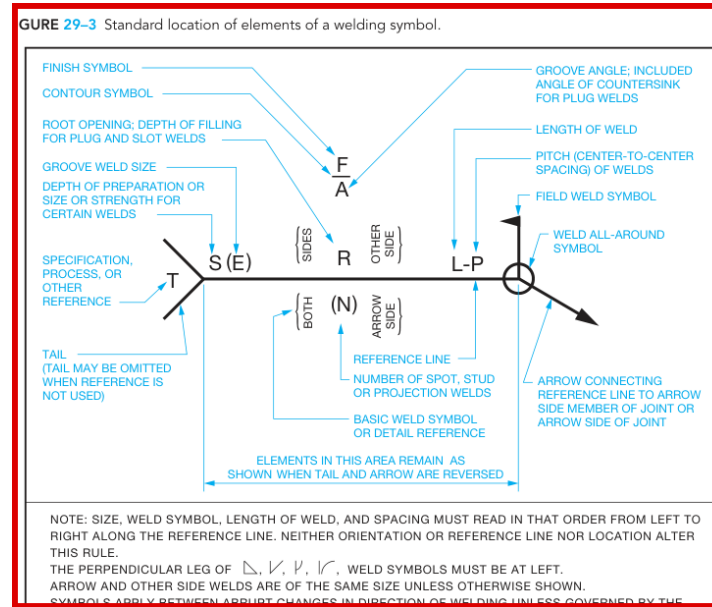

Basis in schema: NASA weldment dimensioning/tolerancing

18. section_hatch_region

Annotation unit: Continuous hatch area within a sectioned part

Include: Crosshatch indicating cut material

Source: Engineering Drawing and Design (Jensen & Helsel), page 252.

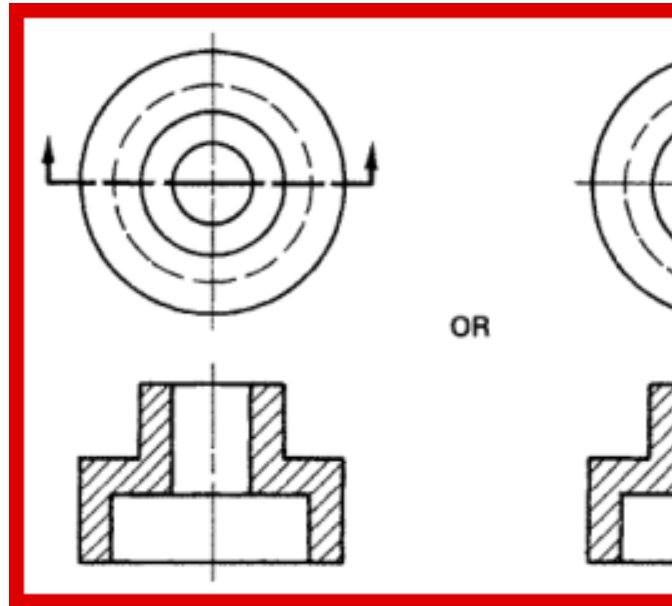

Basis in schema: Workbook section views; NASA allows shaded pictorial views separately